

FICHE TECHNIQUE

LEDST200LA LED SENSOR STREET LIGHTING 200W 7000K



The LED street lights have high brightness, good monochromaticity, soft lighting, high power, long service life, and a luminous time of 25000 hours. LED street lights are not easily damaged, have no thermal radiation, and are beneficial for protecting illuminated objects, with a wide range of applications. The lamp is equipped with a scale plate to adjust the lighting angle, and the LED street light is controlled by a built-in microchip. Generally speaking, it can be aimed in any direction and has a structure that is not affected by climate conditions.

LED street lamp heads are mainly used for lighting on urban expressways, highways, main roads, secondary roads, branches, streets, factories, schools, gardens, parks, residential areas, courtyard squares, and other roads.

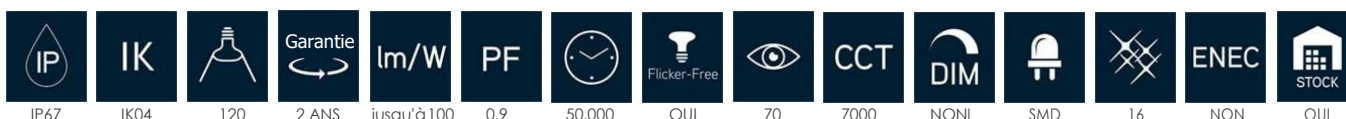

Specifications technique

Reference	LEDST200LA
EAN code	6114561242008
ETIM code	ED240601

Specifications électrique

Puissance système (W)	200
Puissance led (W)	200
Tension (Vac)	85-265Vac
Fréquence (Hz)	50/60
Contrôleur inclus	oui
Contrôleur in/externe	interne
Driver marque	LAZIO
Driver référence	
Dimmable	NON
Flicker free	oui
Power factor	0,9
Câble de connexion	
Driver output (V)	36V
Driver output (mA)	1200mA
Classe d'isolation	I
Classe d'énergie	A+
N° sur disj. 16A type C	
N° sur disj. 16A type D	
Inrush current driver	2A

Garantie et certification

Durée de vie (h)	50.000
Garantie (ans)	2 (hors batteries)
ENEC	no

Propriétés photométriques

Angle rayonnement (°)	120
Temp. de couleur (K)	7000
Rendu de couleurs CRI	70
UGR	16
Solidité de couleurs	3
Sortie de lumen (Lm)	20000
Lm/W	100
HS Code	9405420010
Puce led	SMD
Type led	2835
Nombre de puce led	220

Dimensions et caractéristiques du matériau

Dimensions (LxlxH)	690x230x85mm
Poids (kg)	2.61
Couleur	gris
Temp. de travail (°C)	-20~+45
Valeur IP	IP67
Valeur IK	IK04
Résistant aux UV	oui
Résistant à l'eau de mer	no
UL94	
Nombre en vrac	3
Nombre sur palette	
Quantité minimum	1
Article en stock	oui

FICHE TECHNIQUE

LEDST200LA LED SENSOR STREET LIGHTING 200W 7000K



Température de couleur distributio

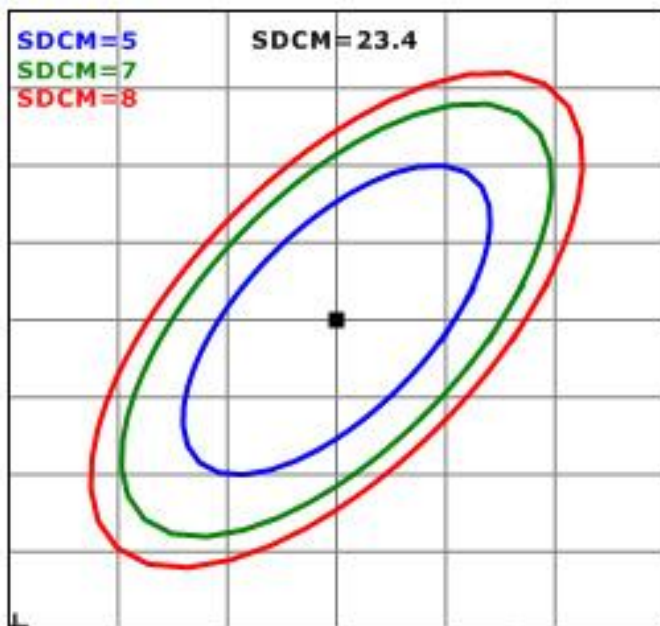

Spectrum distribution

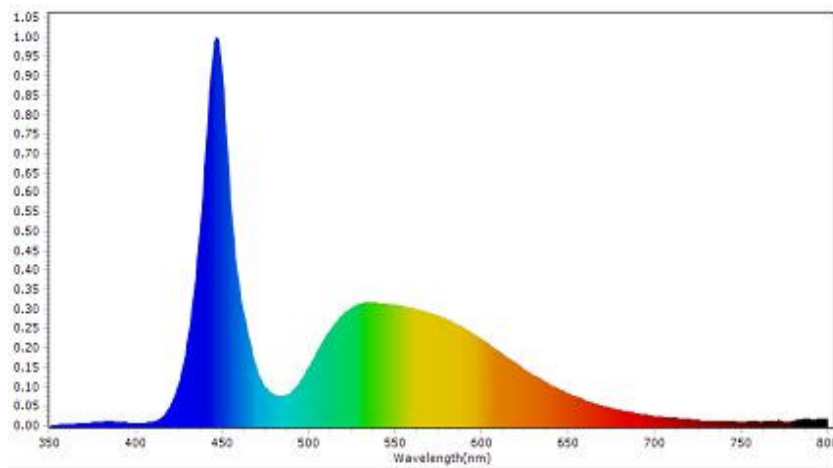

FICHE TECHNIQUE

LEDST200LA LED SENSOR STREET LIGHTING 200W 7000K

Dimensions

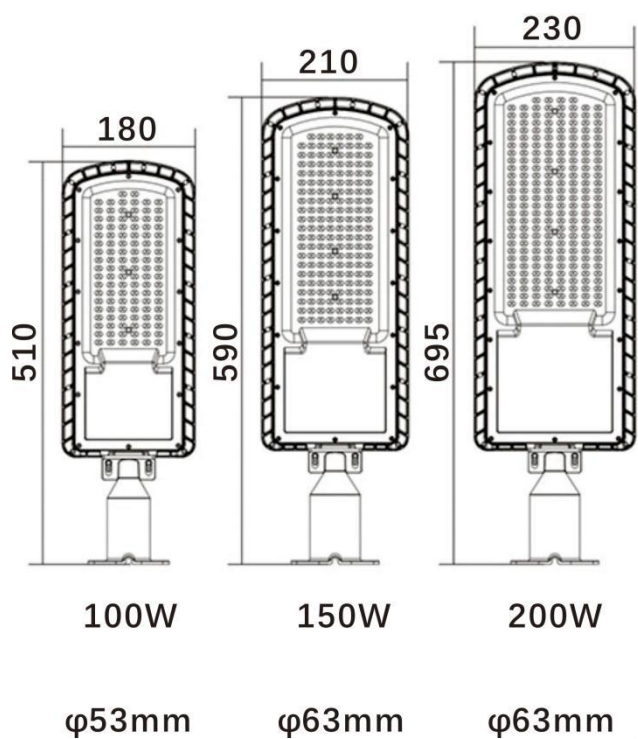

Schème de câblage